



HADEF Druckluft-Kettenzug **Figur 70/06 AP**
HADEF Pneumatic Chain Hoist **Type 70/06 AP**
HADEF Palan Pneumatique à chaîne **Série 70/06 AP**





Standardmäßig/ Serial model/ Modèle de palan standard avec:

- Geräteschutz durch Rutschkupplung (AP 4-8)
Hoist protection by slipping clutch (AP 4-8)
Limiteur de charge à friction (AP 4-8)
- Überlastsicherung durch Luftabschaltung (AP 9)
Overload protection by main air supply cut-off (AP 9)
Limiteur de charge par coupure d'air (AP 9)
- Indirekte Steuerung/ Pilotsteuerung
Indirect control/ pilot control
Commande indirecte
- AP 4 optional mit feinfühligere Direktsteuerung, ohne Mehrpreis.
AP 4 optionally with precision direct control, without add. price.
AP 4 en option avec commande progressive directe, sans prix sup.
- AP 9 - Endschalter Heben/Senken
AP 9 - limit switch lifting/lowering
AP 9 - fin de course haut et bas



Verzinkte RUD Hochleistungs-
lastkette nach EN 818-7-T mit
optimierten Toleranzen.
Zinc plated high quality RUD
load chain acc. to EN 818-7-T
with improved tolerances.
Chaîne de charge zinguée de
haute qualité conforme à la
norme EN 818-7-T, optimisée
pour le palan.

optional ohne Mehrpreis bis EX-Klasse:
optionally without add. price up to EX-class:
en option sans prix sup. jusqu'à classe EX:

CE  II 2G IIB c T4
CE  II 2D c 135°C

Zusätzlich lieferbar:
- Lastkette aus Edelstahl
- funkensichere Ausführung
- bronzierte Haken

As option:
- stainless steel load chain
- sparkproof model
- bronze plated hooks

Equipements optionnels:
- chaîne de charge en inox
- version anti-étincelles
- crochet bronzé

Tragfähigkeit capacity capacité (1) kg	Kettenstränge chain falls brins de chaîne Anzahl No. Nbr.	Lastkette load chain chaîne de charge	Hubgeschwindigkeit Heben/ Senken lifting speed lifting/ lowering vitesses de levage levage/ descente m/min	Leistung output puissance kW	Modell Model Modèle	FEM 9.511 ISO 4301 kw	Luftverbrauch air consumption consommation d'air m³/min	Hauptluftanschluß main air supply alimentation principale en air	Gewicht weight poids	
									3 m kg	+1m Hub lift levée kg
500	1	5x15	8,5/ 22	0,75	AP 405 TI8	2m/M5	1,4	R 1/2"	65	0,6
1000	2	5x15	4,2/ 11,0	0,75	AP 410 TI8	2m/M5	1,4	R 1/2"	75	1,0
1000	1	7x21	8,0/ 15,0	1,5	AP 610 TI15	2m/M5	2,4	R 3/4"	103	1,3
1600	1	9x27	7,0/ 16,0	2,5	AP 716 TI25	2m/M5	3,3	R 1"	128	2,1
2000	2	7x21	4,0/ 7,5	1,5	AP 620 TI15	2m/M5	2,4	R 3/4"	107	2,5
2500	1	11,3x31	3,0/ 6,0	(2)	AP 820 TI35	2m/M5	(2)	(2)	(2)	(2)
3200	2	9x27	3,5/ 8,0	2,5	AP 732 TI25	2m/M5	3,3	R 1"	135	3,9
5000	2	11,3x31	1,5/ 3,0		AP 850 TI35	2m/M5		(2)	(2)	(2)
5000	1	16x45	1,8/ 3,0	2,5	AP 905 TI50	2m/M5	3,3	R 1"	280	6
6300	1	16x45	1,8/ 3,0	2,5	AP 906 TI50	1Bm/M3	3,3	R 1"	280	6
10000	2	16x45	0,9/ 1,4	2,5	AP 910 TI50	2m/M5	3,3	R 1"	370	11,7
12000	2	16x45	0,9/ 1,4	2,5	AP 912 TI50	1Bm/M3	3,3	R 1"	370	11,7
15000	3	16x45	0,6/ 0,9	2,5	AP 915 TI50	2m/M5	3,3	R 1"	450	17,4
20000	4	16x45	0,5/ 0,7	2,5	AP 920 TI50	2m/M5	3,3	R 1"	565	23,1
25000	5	16x45	0,4/ 0,5	2,5	AP 925 TI50	2m/M5	3,3	R 1"	605	28,8
30000	6	16x45	0,3/ 0,5	2,5	AP 930 TI50	2m/M5	3,3	R 1"	(2)	(2)

(1) Bei 6 bar Luftdruck./ With air pressure 6 bar./ A 6 bar de pression de marche. (2) auf Anfrage/ on request/ sur demande



70/06 APS
Ausführung mit Aufhängeöse
Hoist with suspension eye
Palan fixe à oeillet

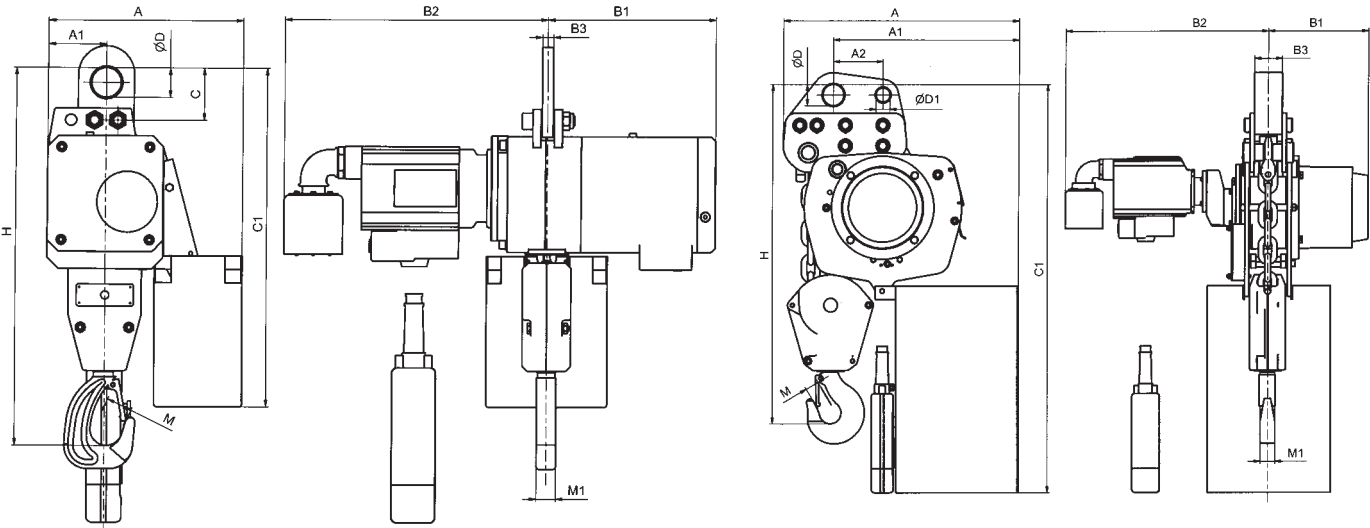

AP 4 – AP 8

AP 9

Modell Model Modèle	Ketten- stränge chain falls brins de chaîne Anzahl no. Nbr.	Lastkette load chain chaîne de charge mm	Hauptmaße in mm main dimensions in mm dimensions principales en mm															
			A	A1	A2	B1	B2	B3	C	C1	D	D1	H	M	M1			
			AP 405	1	5x15	290	55	---	225	451	11	40	425	40	---	400	23	17
			AP 410	2	5x15	290	78	---	225	451	11	40	425	40	---	460	29	22
AP 610	1	7x21	320	62	---	265	462	15	80	560	55	---	540	29	22			
AP 716	1	9x27	364	64	---	312	532	15	75	635	55	---	620	39	29			
AP 620	2	7x21	320	97	---	265	462	15	80	560	55	---	640	39	29			
AP 820	1	11,3x31	364	58	---	312	(1)	20	70	630	55	---	590	48	36			
AP 732	2	9x27	364	108	---	312	532	20	70	635	55	---	710	48	36			
AP 832 AP 850	2	11,3x31	364	108	---	312	(1)	20	70	630	55	---	690	41	45			
AP 905 AP 906	1	16x45	635	412	72	290	690	105	70	993	52	33	755	40	45			
AP 910 AP 912	2	16x45	635	486	146	290	690	80	148	1075	61	41	940	49	63			
AP 915	3	16x45	720	553	217	290	690	80	157	1100	61	41	1130	55	67			
AP 920	4	16x45	850	630	290	290	690	80	185	1230	71	61	1170	55	67			
AP 925	5	16x45	980	705	370	290	690	80	205	1360	76	61	1270	62	75			
AP 930	6	16x45	(1)	(1)	(1)	(1)	(1)	(1)	(1)	(1)	(1)	(1)	(1)	(1)	(1)			

(1) auf Anfrage/ on request/ sur demande



70/06 APR + APH

Ausführung mit Einschienen Roll- oder Haspelfahrwerk

Hoist with monorail push travel or hand geared trolley

Palan avec chariot monorail à poussée ou à avance par chaîne

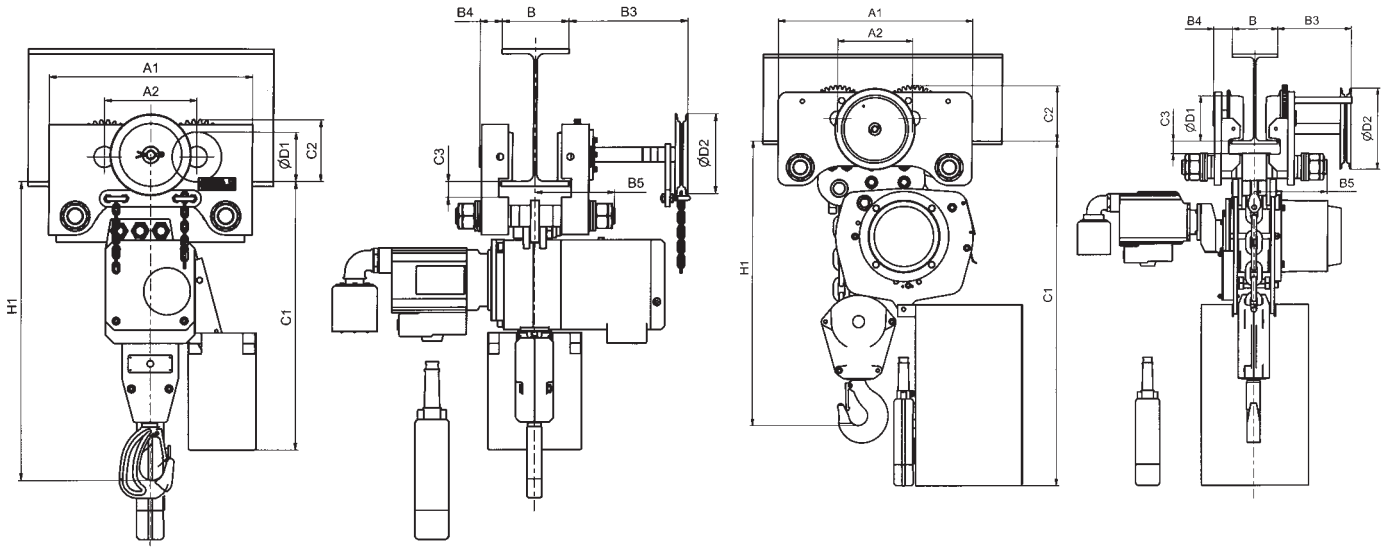

AP 4 - AP 8

AP 9

Modell	Kettenstränge	B Flanschbreite von - bis bei Lastbolzengröße flange width from - to for load bar size largeur de fer de - à pour traverse taille		Hauptmaße in mm											
				main dimensions in mm											
				dimensions principales en mm											
Model	chain falls			A1	A2	B3	B4	B5 (1N)	B5 (2N)	C1	C2	C3	D1	D2	H1
Modèle	brins de chaîne	1 N mm	2 N mm												
	Anzahl no Nbr.														
AP 405	1	50-135	136-220	287	142	272	31	122	166	450	83	25	65	135	393
AP 410	2														453
AP 610	1	66-185	186-310	350	172	281	40	169	230	590	107	31	85	135	510
AP 716	1	74-196	197-310	428	209	284	46	181	240	610	150	32	120	135	625
AP 620	2	66-185	186-310	350	172	281	40	169	230	590	107	31	85	135	610
AP 820	1	74-196	197-310	428	209	284	40	169	230	640	150	32	120	135	600
AP 732	2	74-196	197-310	428	209	284	46	181	240	640	150	32	120	135	710
AP 832	2	74-196	197-310	428	209	284	46	181	240	640	150	32	120	135	690
AP 850	2	74-192	193-310	492	223	278	53	188	190	650	150	38	120	195	710
AP 905	1	119-215	216-312	650	253	248	62	229	276	940	185	42	150	270	721
AP 906															721
AP 910	2	119-215	216-312	650	253	248	62	229	276	940	185	42	150	270	940
AP 912															940
AP 915	3	160-310	-	975	380	288	103	290	---	990	272	43	250	365	1090
AP 920	4	160-310	-	975	380	288	103	290	---	990	272	43	250	365	1145
AP 925	5	160-310	-	1100	432	178	102	290	---	1040	341	43	300	440	1230
AP 930	6	160-310	-	(1)	(1)	(1)	(1)	(1)	(1)	(1)	(1)	(1)	(1)	(1)	(1)

(1) auf Anfrage/ on request/ sur demande



70/06 APP

Ausführung mit Einschiene Druckluftfahrwerk

Hoist with monorail pneumatic trolley

Palan avec chariot monorail pneumatique

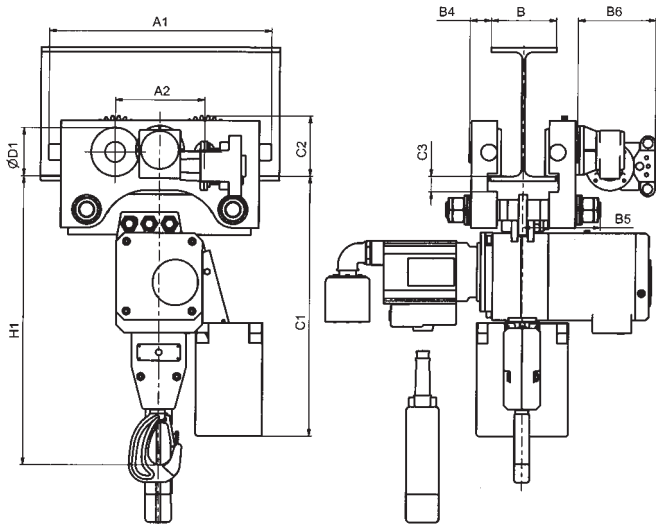

AP 4 – AP 8

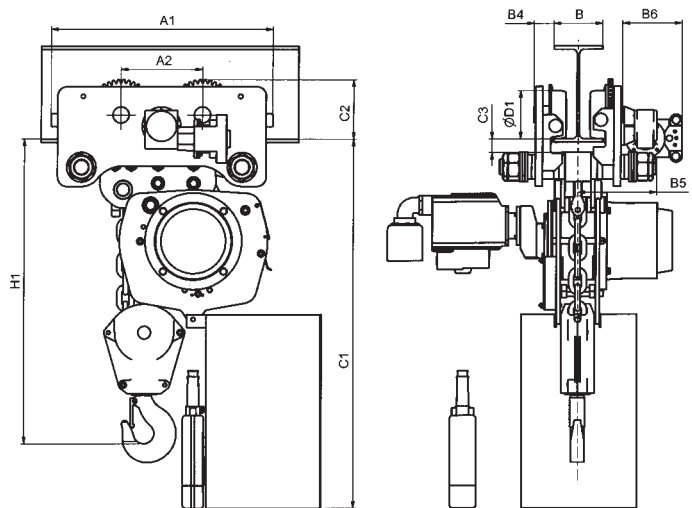

AP 9

Modell	Kettenstränge	B		Gewicht ohne Kettenzug bei 3 m Aufhängehöhe	Fahrmotorleistung	Hauptmaße in mm											
		Flanschbreite von - bis bei Lastbolzengröße				ca. approx. env. kg	kW (2) (3)	main dimensions in mm									
		flange width from - to for load bar size						dimensions principales en mm									
		1 N mm	2 N mm					A1	A2	B4	B5 (1 N)	B5 (2 N)	B6	C1	C2	C3	D1
AP 405	1	50-135	136-220	39,4	0,75	337	142	31	122	166	210	450	83	25	65	393	
AP 410	2															453	
AP 610	1	66-185	186-310	55,2	0,75	400	172	40	169	230	210	530	107	31	85	510	
AP 716	1	74-196	197-310	84,4	0,75	488	209	46	181	240	210	640	150	32	120	625	
AP 620	2	66-185	186-310	55,2	0,75	400	172	40	169	230	210	530	107	31	85	610	
AP 820	1	74-196	197-310	84,4	0,75	488	209	40	169	230	210	640	150	32	120	600	
AP 732	2	74-196	197-310	84,4	0,75	488	209	46	181	240	210	640	150	32	120	710	
AP 832	2	74-196	197-310	84,4	0,75	488	209	46	181	240	210	640	150	32	120	690	
AP 850	2	74-192	193-310	96,8	0,75	552	223	53	188	190	210	650	150	38	120	710	
AP 905	1	119-215	216-312	185,5	0,75	714	253	62	229	276	190	940	185	42	150	721	
AP 906																721	
AP 910	2	119-215	216-312	(1)	0,75	714	253	62	229	276	190	940	185	42	150	940	
AP 912																940	
AP 915	3	160-310	-	(1)	0,75	1039	380	103	290	---	190	990	272	43	250	1090	
AP 920	4	160-310	-	(1)	0,75	1039	380	103	290	---	190	990	272	43	250	1145	
AP 925	5	160-310	-	(1)	0,75	1164	432	102	290	---	190	1040	341	43	300	1230	
AP 930	6	160-310	-	(1)	(1)	(1)	(1)	(1)	(1)	(1)	(1)	(1)	(1)	(1)	(1)	(1)	

(1) auf Anfrage/ on request/ sur demande

(2) Fahrgeschwindigkeit/ trolley speed/ vitesse chariot = 8 m/min

(3) Luftverbrauch/ air consumption/ consommation d'air = 1,2 m³/min